



6068DF150

POWERTECH

SPECIFICATIONS

For Variable Speed

JOHN DEERE

Power Units

Tier-1 Emission Certifications:

CARB; EPA; EU

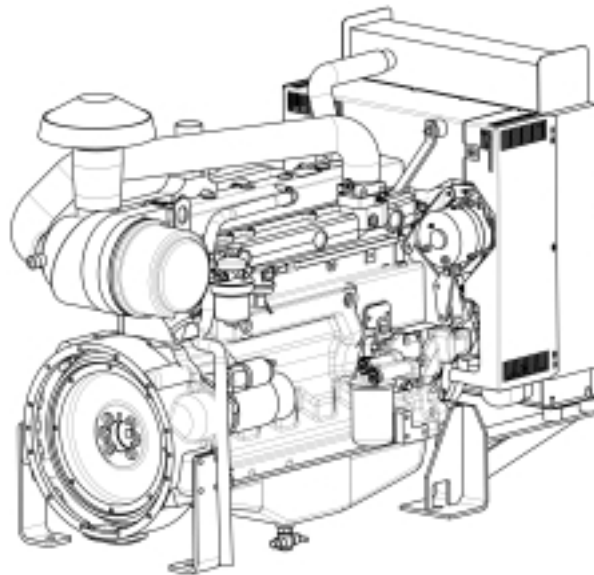

Performance Data

Gross Rated Power (without fan) – kW (hp)	[C]..... 84 (113)
	[I] 93 (125)
Rated Speed – rpm 2500
Peak Torque – N•m (lb-ft)	[C]..... 403 (297)
	[I] 448 (330)
Peak Torque Speed – rpm 1200
Low Idle Speed – rpm 850
BMEP – kPa (psi)	[C]..... 594 (86)
	[I] 657 (95)
Friction Power @ Rated Speed – kW (hp) 34 (46)
Altitude Capability – m (ft) 300 (1000)
Air: Fuel Ratio	[C]..... 22.6 : 1
	[I] 20.5 : 1
Smoke @ Rated Speed – Bosch No.	[C]..... < 2
	[I]..... < 2
Noise – dB(A) @ 1 m	[C]98
	[I]98

Engine Speed rpm	Contin. Limit kW (hp)	Intermit. Power kW (hp)	Intermit. Torque N•m (lb-ft)	BSFC g/kWh (lb/hp-hr)
2500	84 (113)	93 (125)	355 (262)	236 (0.387)
2400	83 (111)	92 (123)	365 (269)	233 (0.382)
2200	80 (107)	89 (119)	386 (285)	228 (0.374)
2000	76 (102)	84 (113)	402 (296)	223 (0.366)
1800	70 (94)	78 (105)	416 (307)	220 (0.361)
1600	65 (87)	72 (96)	428 (316)	218 (0.356)
1400	58 (78)	65 (87)	440 (325)	218 (0.356)
1200	51 (68)	56 (75)	448 (330)	220 (0.361)
1000	-	47 (63)	448 (330)	224 (0.367)

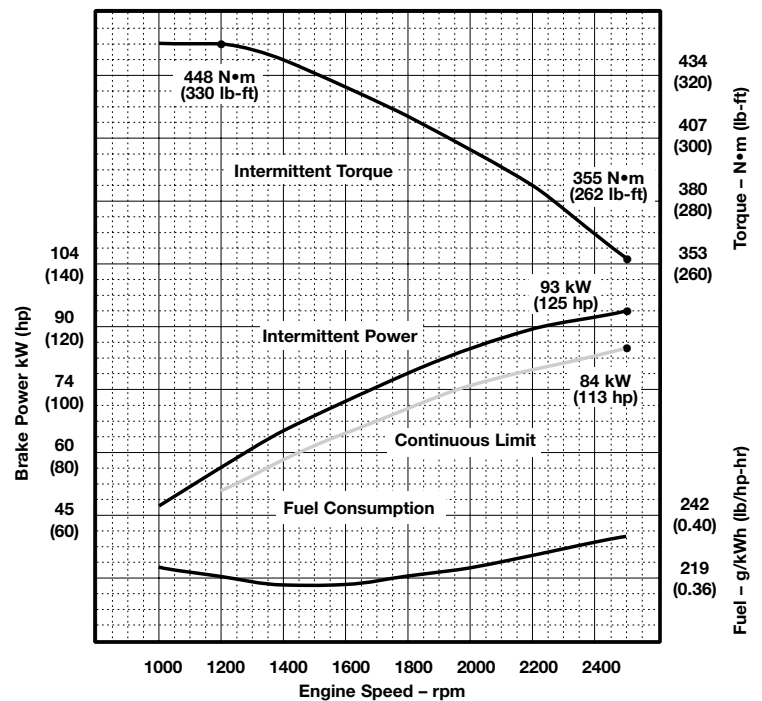

Gross power guaranteed within + or - 5% at SAE J1995 and ISO 3046 conditions:
 77 °F (25 °C) air inlet temperature
 29.31 in.Hg (99 kPa) barometer
 104 °F (40 °C) fuel inlet temperature
 0.853 fuel specific gravity @ 60 °F (15.5 °C)

Conversion factors:

- Power: kW = hp x 0.746
- Fuel: 1 gal = 7.1 lb, 1 L = 0.85 kg
- Torque: N•m = lb-ft x 1.356

Photographs may show non standard equipment.



Power Unit Specification Data

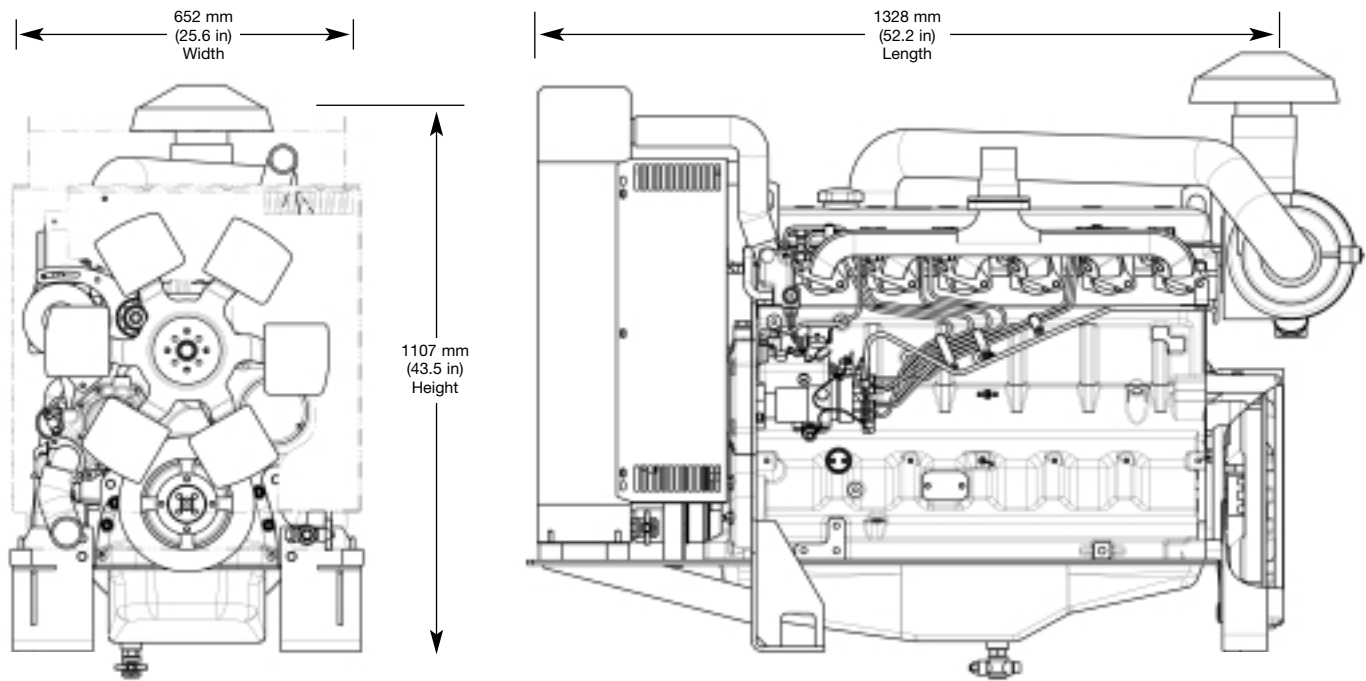

General Data

Model	6068DF150
Number of cylinders	6
Bore and Stroke – mm (in.).....	106 x 127 (4.19 x 5.00)
Displacement – dm ³ (in ³)	6.8 (414)
Compression Ratio.....	17.6 : 1
Valves per Cylinder – Intake/Exhaust	1 / 1
Firing Order	1-5-3-6-2-4
Combustion System	Direct Injection
Engine type	In-line, 4-cycle
Aspiration	Natural
Engine Crankcase Vent System	Open
Engine Crankcase Pressure – kPa (in.H ₂ O)	0.5 (2)

Physical Data

Length – mm (in.)	1328 (52.2)
Width – mm (in.)	652 (25.6)
Height – mm (in.)	1107 (43.5)
Weight, dry – kg (lb)	643 (1417)
(Includes flywheel housing, flywheel, & electrics)	
Center of gravity location	
From Rear Face of block (X-axis) – mm (in.)	433 (17.0)
Right of Crankshaft (Y-axis) – mm (in.)	-1 (-0.05)
Above Crankshaft (Z-axis) – mm (in.)	157 (6.2)
Max. Allow. Static Bending Moment at Rear	
Face of Flywheel Hsg w/ 5-G Load – N•m (lb-ft)	814 (600)
Thrust Brng. Load Limit (Forward) – N (lb) [C]	2224 (500)
[I]	4003 (900)

Electrical Data

Recommended Battery Capacity (CCA)	
12 Volt System – Amp	800
24 Volt System – Amp	570
Maximum Allowable Starting Circuit Resistance	
12 Volt System – Ohm	0.0012
24 Volt System – Ohm	0.002
Starter Rolling Current – 12 Volt System	
At 0°C (32°F) – Amp	920
At -30°C (-22°F) – Amp	1300
Starter Rolling Current – 24 Volt System	
At 0°C (32°F) – Amp	600
At -30°C (-22°F) – Amp	700

Specifications and design subject to change without notice.

Air System

Maximum Allowable Temperature Rise	
Ambient Air to Engine Inlet – °C (°F)	8 (15)
Maximum Air Intake Restriction	
Dirty Air Cleaner – kPa (in. H ₂ O)	6.25 (25)
Clean Air Cleaner – kPa (in. H ₂ O)	3 (12)
Engine Air Flow – m ³ /min (ft ³ /min) [C]	6.5 (229)
[I]	6.5 (229)

Exhaust System

Exhaust Flow – m ³ /min (ft ³ /min) [C]	17.9 (632)
[I]	19 (670)
Exhaust Temperature – °C (°F) [C]	580 (1076)
[I]	630 (1166)
Max. Allow. Back Pressure – kPa (in.H ₂ O).....	7.5 (30)
Recommended Exhaust Pipe Dia – mm (in.)	102 (4.0)

Cooling System

Thermostat Start to open – °C (°F)	82 (180)
Power Unit Coolant Capacity – L (qt)	28 (29.5)
Minimum Air to Boil temperature – °C (°F)	47 (117)

Fuel System

Fuel Injection Pump	Lucas
Governor Regulation.....	7 – 10%
Governor Type	Mechanical
Fuel Consumption – kg/hr (lb/hr) [C].....	19.7 (43.3)
[I]	21.8 (48)
Total Fuel Flow – kg/h (lb/h)	104 (229)
Maximum Fuel Transfer Pump Suction – m (ft)	0.9 (3)
Fuel Filter Micron Size @ 98% Efficiency	8

Lubrication System

Oil Pressure at Rated Speed – kPa (psi)	345 (50)
Oil Pressure at Low Idle – kPa (psi).....	105 (15)
In Pan Oil Temperature – °C (°F)	115 (240)
Oil Pan Capacity, Low – L (qt)	15.1 (16)
Oil Pan Capacity, High – L (qt)	16.1 (17)
Total Engine Oil Capacity with filter – L (qt)	17 (18)
Engine Angularity Limits, Any Direction – degrees [C]	20
[I]	30



John Deere Power Systems
La Foulonnerie
 Usine de Saran – B.P. 11013
 45401 Fleury les Aubrais Cedex – France

Tel.: (33) 2 38 82 61 19
 Fax: (33) 2 38 84 62 66
 http: www.deere.com/jdpower

